



Presto Stantest Pvt. Ltd.

I-42, DLF Industrial Area Phase-1, Delhi Mathura Road, Faridabad 121003, Haryana, India
P : 9210 903 903, +91 129 4272727, 93111 24302 E : info@prestogroup.com

- Faridabad • Kolkata • Mumbai • Pune • Ahmedabad
- Chennai • Bangalore • Hyderabad



Hot Water Bath - Digital



Microprocessor based
PID temperature controller

Model No. PWBD 0136

Water Bath Digital is a unique test cabinet designed to detect the change in the physical characteristics of material and to ascertain the actual working life of test samples at elevated temperature.

Available in Digital PID Temperature Control Models with Timer facility (optional) with various capacities.

- Temperature control through PT-100 sensor
- Highly accurate test results under uniform temperatures in the chamber
- Advanced Digital Microprocessor based PID temperature controller
- Provision of Set Value(SV) and Process Value(PV) on temperature display
- Inbuilt Auto tuning function
- Bright LED display
- Equipped with rapid heaters for uniform and homogenous heating and maintaining temperature inside the chamber
- Integral water drain system
- Inbuilt Calibration feature with reference to master PID controller
- Setting to RTD PT-100 sensor through advanced PID controller
- Stirrer motor for precise stirring of sample inside the tank and for uniformity of temperature
- Speed regulator for controlling the speed of stirrer

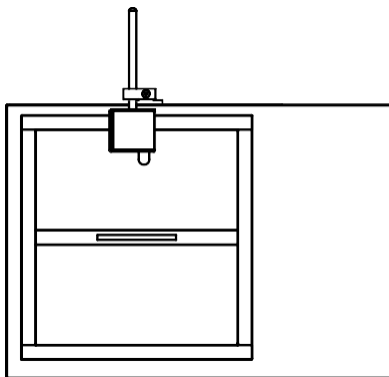

Top View

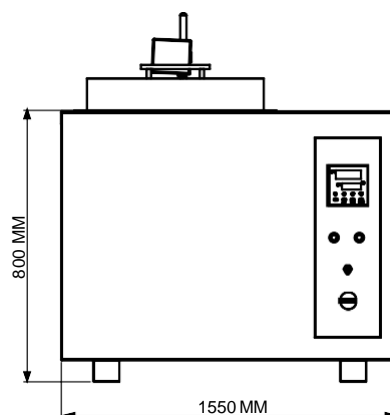

Front View

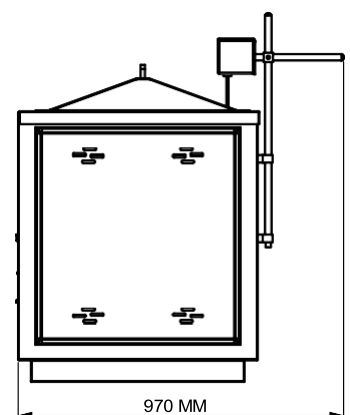

Side View



Presto Stantest Pvt. Ltd.

I-42, DLF Industrial Area Phase-1, Delhi Mathura Road, Faridabad 121003, Haryana, India
P : 9210 903 903, +91 129 4272727, 93111 24302 E : info@prestogroup.com



- Faridabad • Kolkata • Mumbai • Pune • Ahmedabad
- Chennai • Bangalore • Hyderabad

It is used to incubate samples in hot water at high temperatures required in textile and microbiology industries. The Water Bath Digital comes with Water circulation pump for maintaining heating efficiency.

Key Specifications:

Inner Size	L 1200 x W 600 x H 600 mm
Display	LED (Digital) 7 segment
Accuracy	± 2°C
Least Count/Resolution	1°C
Power	3 phase with Neutral, 50 Hz, 20A Power socket
Water circulation	Yes, Water circulation Pump
Water drain	1/4 ball valve
Temperature Range	Upto 90°C
Heater Wattage	3 Kw x 3 nos.

Highlights:

Temperature Sensor	PT 100
Top Cover	Yes
Material	Mild Steel (Outer Body) Stainless Steel (Inner Body)
Finish	Powder coated Havel Gray & Blue combination finish and bright chrome / zinc plating for corrosion resistant finish
Dimensions outer	L 1550 x W 970 x H 800 mm approx

Optional Features :

- Water Bath with timer facility
- Other size also available as per requirement.

Thank you customers for choosing us as your partners in growth !



*All the above logos are the sole property of their respective owners and are used purely for depiction purposes only.

OUR OTHER PRODUCTS :-

Hot Air Oven Prima	Humidity Chamber	Cupping Machine	Salt Spray Chamber Korrox - III	Scratch Hardness Tester Motorised	Tensile Testing Machine

